

Line Station Valves 7160 Series

Application

The 7160 series valves are designed for use with oxygen and all fuel gases at station outlets of line distribution systems such as welder's benches, cutting stations, hospital rooms, etc.

Features

- UL Listed Approved for oxygen and all fuel gas services at 400 PSIG maximum working pressure.
- All valves cleaned for use in oxygen per CGA G-4.1
- O-ring stem seal works with the pressure causing a tighter seal as pressure increases.
- A reverse flow check valve installed in the valve outlet connection helps prevent reverse flow.
- Available with brass cap and chain protection.
- Meets the requirements of National Fire Protection Association (NFPA) Pamphlet No. 51.



Materials

Body	Brass
Stem and Seat Retainer	Brass
O-ring.....	Neoprene
Seat Disc.....	Nylon
Reverse Flow Check Seat.....	Neoprene

7160 Series

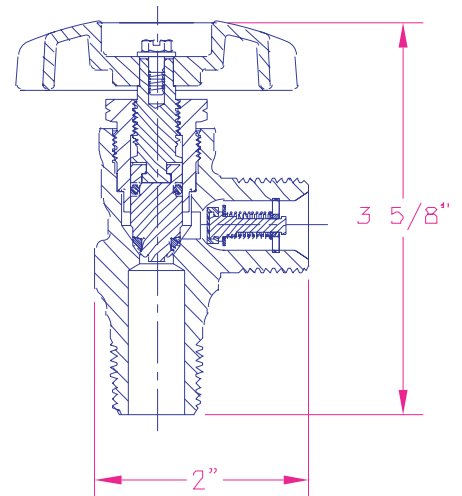

Ordering Information

Part Number	Gas Service	Inlet Thread	Outlet Thread	CGA Connection	C _v Factor	Outlet Protection*
7160V	Oxygen and Inert Gases	½" NGT	7/8" - 14 M. R.H.	024	.76	10663 Brass Cap & Chain
7160VL						None
7161V	Fuel Gases		7/8" - 14 M. L.H.	025		10664 Brass Cap & Chain
7161VL						None

*Outlet Protection is recommended.