

Cryogenic Gas Relief Valves, ASME PRV19430 & PRV29430 Series

Application

The 19430 and 29430 relief valves are designed for oxygen and other industrial gases and for cryogenic service in the vapor space. Apply on piping systems, liquid cylinders or mini-bulk cryogenic containers where an ASME relief valve is required.

Features

- A.S.M.E. rated, National Board Certified
- Bubble tight at 95% of set pressure
- Full flow at 110% at set pressure
- Repeatable performance
- 100% factory tested
- Temperatures Range (Teflon Seat) -320° to +165° F (-196°C to +74°C)
(Fluorosilicone Seat) -60° to +165° F (-51°C to +74°C)
- Cleaned and packaged for oxygen service per CGA G-4.1
- Rated for gas service only
- Color coded labels clearly identify pressure setting range
- Tamper resistant
- In liquid service be sure to use with a candy cane riser (Sold Separately)

Materials SS Style

Body	Stainless Steel
Spring	Stainless Steel
Seat Retainer.....	Stainless Steel
Pipe-Away Adapter	Stainless Steel

Materials PRV and B-Style

Body	Brass
Spring	Stainless Steel
Seat Retainer.....	Brass
Pipe-Away Adapter	Brass

Flow Performance

For set pressures 90 - 600 capacity is 0.692 SCFM of air per psig of flow pressure. For set pressures 15 - 89 capacity is 0.750 SCFM of air per PSIA of flow pressure. Flow pressure per ASME is 10% above set pressure or +3 psig (0.2 barg), whichever is greater.

Ordering Information

Fill in the blanks with options below.

Example: PRV019432T350

PRV	1	9432	T	Blank or "P"	350
Style	Body Material	Size	Seat Material	Drain Hole	Set Pressure

Body Material Option

- 1 ASME approved valve made of brass
- 2 ASME approved valve made of stainless steel

Seat Material Option

- F for Fluorosilicone for 15 to 139 psig (6.2 - 9.5 barg) set points.
T for PTFE for 140-600 psig (9.6 - 41.4 barg) set points.

Drain Hole Option

Leave blank for relief with drain hole. Insert P if no drain hole.

Set Pressure

Enter number for set pressure in psig (6.2 - 41.4 barg) from 15 to 600.

Ordering Information

Part Number	Body and Valves Material	Pressure Setting Range psig (barg)	Inlet MNPT A Inches (mm)	Height B Inches (mm)	Wrenching Hex C inches (mm)	Kd value	Orifice Size In2 (mm2)
PRV19432	Brass	15-600 (1.03-41.36)	¼" (6.35)	2.6" (66.04)	⅝" (22.35)	0.686	.062 (40)
PRV29432	Stainless Steel						
PRV19433	Brass		⅜" (9.65)				
PRV29433	Stainless Steel						
PRV19434	Brass		½" (12.70)	2.8" (71.12)			
PRV29434	Stainless Steel						

Pipe-away adapter options available (sold separately)
Drain hole can not be used with pipe-away



19430 Series

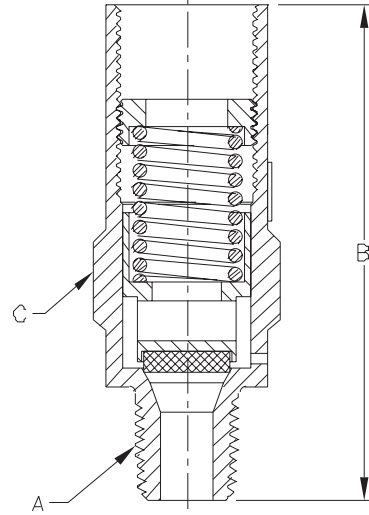

The use of a candy cane riser is recommended for liquid phase installation of these PRVs.

Setpoint tolerance is ± 3% of the set pressure or ± 2 psig whichever is greater.

WARNING: Inspection and maintenance of pressure relief valves is very important. Failure to properly inspect and maintain pressure relief valves could result in personal injuries or property damage. The useful safe service life of a pressure relief valve may be significantly affected by the service environment.

Pressure Setting and Flow Data PRV19430 and PRV29430 Series

Pressure Setting and Flow Data PRV19430 and PRV29430 Series								
Pressure Setting psig	barg	Air Flow Capacity SCFM	Pressure Setting psig	barg	Air Flow Capacity SCFM	Pressure Setting psig	Barg	Air Flow Capacity SCFM
15	1	25	215	14.8	174	450	31	353
20	1.4	28	220	15.2	178	460	31.7	360
22	1.5	30	225	15.5	181	470	32.4	368
25	1.7	32	230	15.9	185	480	33.1	376
30	2.1	36	235	16.2	189	490	33.8	383
35	2.4	40	240	16.5	193	500	34.5	391
40	2.8	44	250	17.2	200	510	35.2	398
45	3.1	48	260	17.9	208	520	35.9	406
50	3.4	52	270	18.6	216	530	36.5	414
55	3.8	56	275	19	220	540	37.2	421
60	4.1	61	280	19.3	223	550	37.9	429
65	4.5	65	285	19.7	227	560	38.6	436
70	4.8	69	290	20	231	570	39.3	444
75	5.2	73	300	20.7	239	580	40	452
80	5.5	77	310	21.4	246	590	40.7	459
85	5.9	81	320	22.1	254	600	41.4	467
90	6.2	79	325	22.4	258			
100	6.9	86	330	22.8	261			
110	7.6	94	340	23.4	269			
120	8.3	102	350	24.1	277			
125	8.6	105	360	24.8	284			
130	9	109	370	25.5	292			
140	9.7	117	375	25.9	296			
150	10.3	124	380	26.2	299			
160	11	132	390	26.9	307			
170	11.7	140	400	27.6	315			
175	12.1	143	410	28.3	322			
180	12.4	147	420	29	330			
190	13.1	155	425	29.3	334			
200	13.8	162	430	29.6	337			
210	14.5	170	440	30.3	345			

Color Identification

22 psig	230 psig
35 psig	350 psig
50 psig	450 psig
100 psig	500 psig
150 psig	

Color Identification

1.51 barg	15.85 barg
2.41 barg	24.13 barg
3.44 barg	31.02 barg
6.89 barg	34.47 barg
10.34 barg	

ASME Ordering Information

